

PODS CATALOGUE

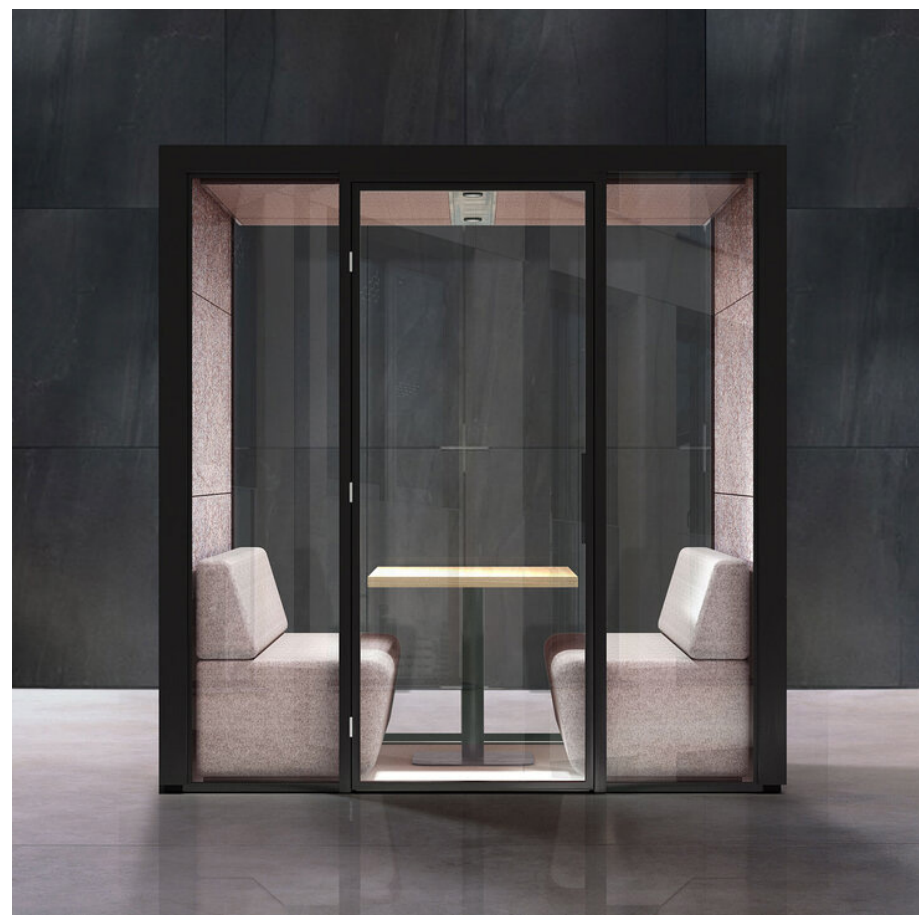

INDEX

We are sustainable and social	page 02
Eco pod collection	page 03
Duo pod	page 04 - 06
Meeting pod	page 07 - 09
Meeting pod large	page 10 - 11
Meeting pod XL	page 13 - 14
Work pod & Work pod large	page 17 - 18
Work pod XL	page 19 - 20
Flex pod	page 21 - 22
Phone pod	page 23 - 24
Extending pods	page 26 - 27
Connecting together	page 28 - 29
Door and wheelchair accesibility	page 30
Flexible interior & exterior options	page 31 - 33
Lighting & ventilation	page 34
Electrification & cable management	page 34
Power socket options	page 35
Acoustic performance	page 36
Recycled material	page 37
Make your own	page 38
Outside panels	page 39
Inside panels	page 40
Soto	page 41
Rebo	page 42
Felt	page 43
Organi	page 44
Wooly	page 45
Main Line Flax	page 46
Blazer	page 47
Wood panels	page 48
Alternative panels	page 49
Tables & shelves	page 50
Sustainable packaging	page 51
General terms of delivery	page 52 - 53





SUSTAINABILITY AND SOCIAL AWARENESS

The world is changing faster than ever before. Climate change is forcing us to design and manufacture products in a different way with more awareness of the impact on our environment and society. These two principles are strongly related and determine the pillars of our organization. Making sustainable products with social consciousness.

We believe in a circular economy where the lifetime of a product is extended to the max, but also the lifetime of a person is respected and improved. We do not only care of the people that will use our products, but also the people who are involved in the making of it. Taking care of our planet and the people that live on it is our mission.

Our big range of modular pods will guarantee the maximum flexibility that is required for the modern public or commercial environment that is changing all the time. The interchangeable components can be replaced and reused again because all parts are locally made and easy to adapt. Modularity and local production are the fundamentals of our circular way of manufacturing. Removable fabric covers, wall panels that can be changed for integrated tables, pods that can be connected, colors that match any corporate identity, our pods secure the needs of a long-term investment.

Explore more about the different sizes, carefully selected recycled materials and integrated technology.

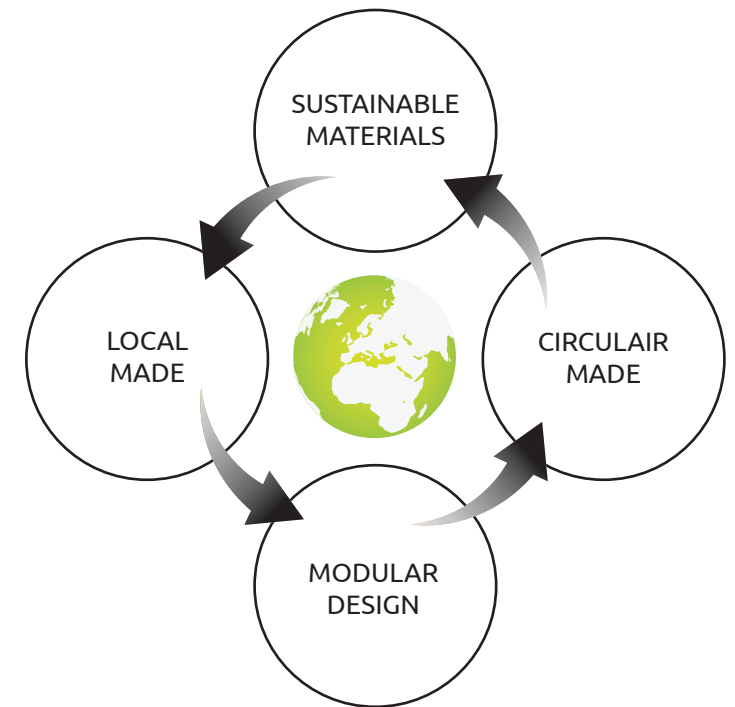

ECO POD COLLECTION



PHONE POD

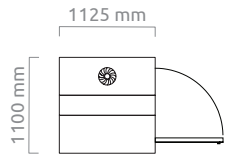

FLEX POD

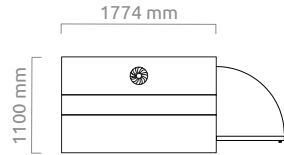

WORK POD

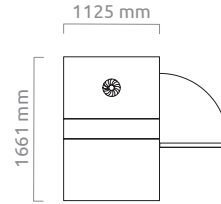

WORK POD LARGE

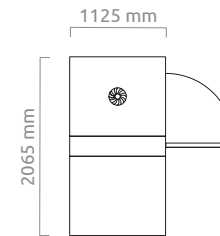

WORK POD XL

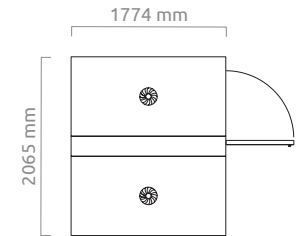

DUO POD

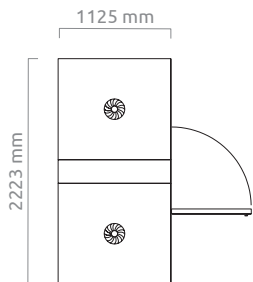

MEETING POD

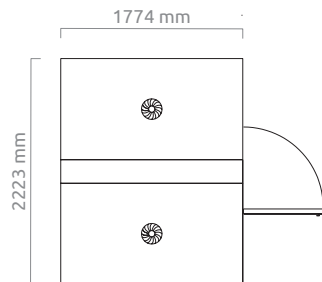

MEETING POD LARGE

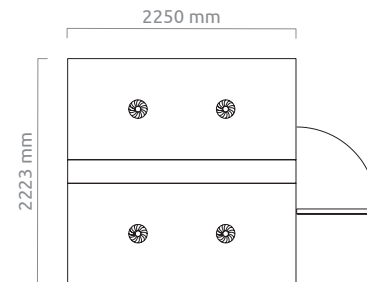

MEETING POD XL

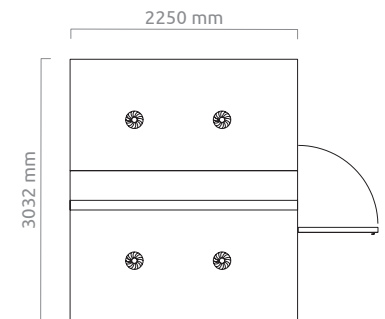





DUO POD

Suitable for 2 to maximum 3 people to fit in.

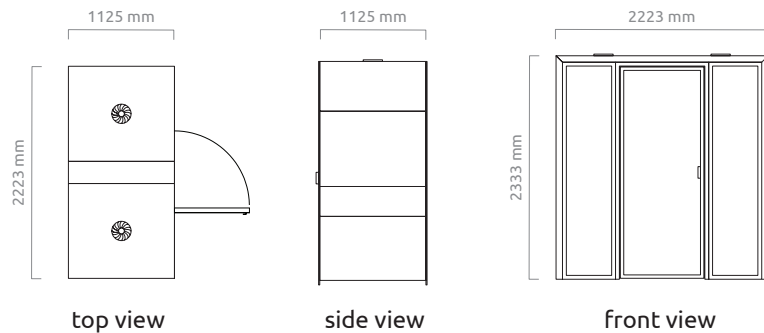

MEETING TABLES

Whether having a meeting at a high table with bar chairs, at a low table, or at a low table with integrated sofas, there are options to integrate technology and to share or present via an LCD screen. Power sockets can be integrated with HDMI-, DATA- or USB ports to connect your laptop or other devices. See page 33.

PANEL INTEGRATION

There are different integration options for the side panels, like an LCD panel with a shelf for the remote control. The back side of the DUO POD is completely transparent, made of three windows with layered glass connected to each other (without a closed panel in between).



MEETING TABLES HIGH

The space inside the Duo-pod offers enough room for two or three bar chairs or two integrated sofas. Bar chairs often require less space than task chairs or visitor chairs.

DUO POD with glass backside



Price category 1:

fabric range soto, rebo

Price category 2:

fabric range wooly, organi, eco felt

Price category 3:

fabric range main line flax, laminated panels outside

Price category 4:

fabric range blazer, laminated acoustic panels inside

Included:

- 2x led-lights 5watt with sensor integrated in ceiling.
- air ventilation integrated in ceiling.
- door with hidden magnet closing.
- 1x integrated power socket.

Optional:

- extra power sockets (see page 33).
- integrated side tables, shelf and sofa.
- integrated magnetic white boards.
- integrated lcd-screen panels.
- water sprinkler integrated on request.

DUO POD with upholstered panel at the backside



Price category 1:

fabric range soto, rebo

Price category 2:

fabric ranges wooly, organi, eco-felt

Price category 3:

fabric range main line flax, laminated panels outside

Price category 4:

fabric range blazer, laminated acoustic panels inside

Included:

- 2x led-lights 5watt with sensor integrated in ceiling.
- air ventilation integrated in ceiling.
- door with hidden magnet closing.
- 1x integrated power socket.

Optional:

- integrated power sockets (see page 33).
- integrated meeting table, side tables, shelves and sofas.
- integrated magnetic white boards.
- integrated lcd-screen panels.
- water sprinkler integrated on request.

OPTIONS for Duo pod



Side table & Shelf short

table 500mm / 1010mm
shelf 250mm / 1010mm

height 1050mm / low 750mm



Meeting table short

low table 750mm
high table 1050mm

top 800mm / 500mm / 40mm



White board short

Dimensions 1120mm x 780mm.
Available for inside or integrated
at the outside of the pods.
Prices upon request.
Available at inside and outside.



LCD-screen panel short

Available upon request for
mounting any LCD-screen
at the inside or outside of
the Duo pod.



Sofa short (see page 31)

fabric category 1
fabric category 2
fabric category 3
fabric category 4





MEETING POD

Suitable for 4 to maximum 6 people to fit in.

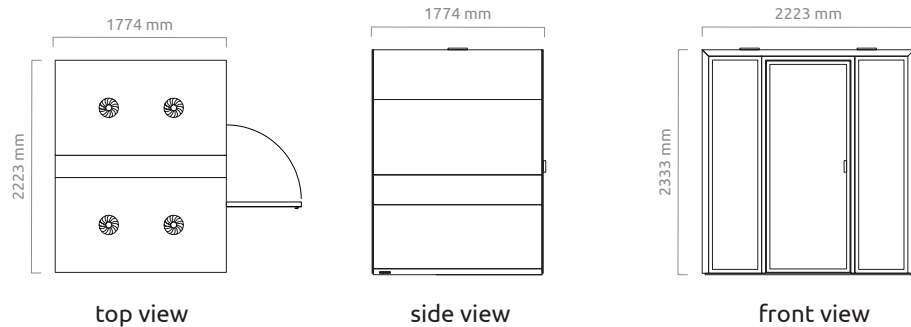

MEETING TABLES

Whether having a meeting at a high table with bar chairs, or at a low table with integrated sofas, there are options to integrate technology and to share or present via an LCD screen. Power sockets can be integrated with HDMI-, DATA- or USB ports to connect your laptop or other devices. See page 33.

BRIDGE TABLE

The Bridge-table can be placed at two different heights depending on if you want to sit at a bar chair or at a chair with casters. At both sides there is an integrated power socket for both users. See page 33.



PANEL INTEGRATION

Various integration options for the side panels exist, like an LCD panel with a shelf for the placement of a remote control. The back side of the DUO POD is completely transparent, made of three windows with layered glass connected to each other (without a closed panel in between).

MEETING POD with glass backside



Price category 1:

fabric range soto, rebo

Price category 2:

fabric range wooly, organi, eco felt

Price category 3:

fabric range main line flax, laminated panels outside

Price category 4:

fabric range blazer, laminated acoustic panels inside

Included:

- 2x led-lights 5watt with sensor integrated in ceiling.
- air ventilation integrated in ceiling.
- door with hidden magnet closing.
- 1x integrated power socket.

Optional:

- extra power sockets (see page 33).
- integrated side tables, shelves and sofas.
- integrated magnetic white boards.
- integrated lcd-screen panels.
- water sprinkler integrated on request.

MEETING POD with upholstered panel at the backside



Price category 1:

fabric range soto, rebo

Price category 2:

fabric range wooly, organi, eco felt

Price category 3:

fabric range main line flax, laminated panels outside

Price category 4:

fabric range blazer, laminated acoustic panels inside

Included:

- 2x led-lights 5watt with sensor integrated in ceiling.
- air ventilation integrated in ceiling.
- door with hidden magnet closing.
- 1x integrated power socket.

Optional:

- extra power sockets (see page 33).
- integrated meeting- side- bridge tables, shelves and sofas.
- integrated magnetic white boards.
- integrated lcd-screen panels.
- water sprinkler integrated on request.

OPTIONS for Meeting pod



Side table long

table 500mm / 1660mm
shelf 250mm / 1660mm

hight 1050mm / low 750mm



Bridge table

2020mm / 700mm

height top 750mm or 1050mm
from floor.



Meeting table long

low 750mm
high 1050mm

top 800mm / 1170mm / 40mm



White board long

Dimensions 1780mm x 780mm.
Available for inside or
integrated at the outside of
the pods.



Sofa long (see page 31)

fabric category 1
fabric category 2
fabric category 3
fabric category 4



LCD-screen panel long

Available upon request for
at the inside or outside of
the pods.



MEETING POD LARGE

Suitable for 6 to maximum 8 people to fit in.

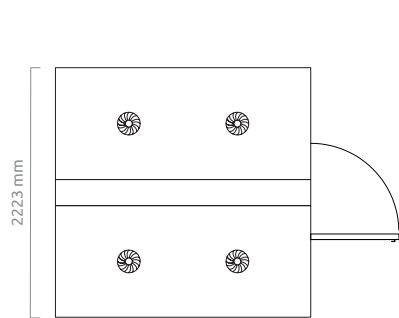

top view

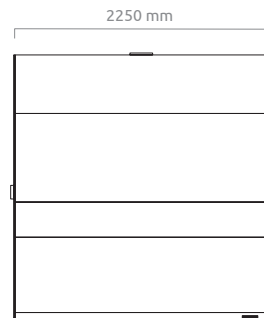

side view

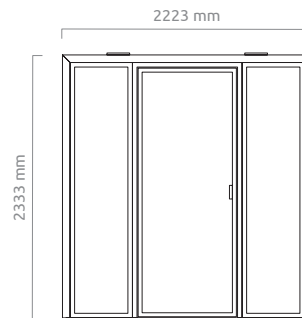

front view



MEETING TABLES

Whether having a meeting at a high table with bar chairs, or at a low table with integrated sofas, there are options to integrate technology and to share or present via an LCD screen. Power sockets can be integrated with HDMI-, DATA- or USB ports to connect your laptop or other devices. See page 33.

PANEL INTEGRATION

Various integration options for the side panels exist, like an LCD panel with a shelf for the placement of a remote control.

The back side of the DUO POD is completely transparent, made of three windows with layered glass connected to each other (without a closed panel in between).



MEETING POD LARGE with glass backside



Price category 1:

fabric range soto, rebo

Price category 2:

fabric range wooly, organi, eco felt

Price category 3:

fabric range main line flax, laminated panels outside

Price category 4:

fabric range blazer, laminated acoustic panels inside

Included:

- 2x led-lights 5watt with sensor integrated in ceiling.
- air ventilation integrated in ceiling.
- door with hidden magnet closing.
- 1x integrated power socket.

Optional:

- extra power sockets (see page 33).
- integrated side tables, shelf and sofa.
- integrated magnetic white boards.
- integrated lcd-screen panels.
- water sprinkler integrated on request.

MEETING POD LARGE with upholstered panel at the backside



Price category 1:

fabric range soto, rebo

Price category 2:

fabric range wooly, organi, eco felt

Price category 3:

fabric range main line flax, laminated panels outside

Price category 4:

fabric range blazer, laminated acoustic panels inside

Included:

- 2x led-lights 5watt with sensor integrated in ceiling.
- air ventilation integrated in ceiling.
- door with hidden magnet closing.
- 1x integrated power socket.

Optional:

- extra power sockets (see page 33)
- integrated meeting table, side tables, shelves and sofas.
- integrated magnetic white boards.
- integrated lcd-screen panels.
- water sprinkler integrated on request.

OPTIONS for Meeting pod LARGE



Side table & Shelf XL

table 500mm / 2140mm
shelf 250mm / 2140mm

high 1050mm / low 750mm



Meeting table XL

low 750mm
high 1050mm

top 800-1000mm / 1570mm / 40mm



White board XL

Dimensions 2140mm x 780mm.
Available for inside or
integrated at the outside of
the pods.



LCD-screen panel XL

Dimensions 2140mm x 780mm.
Available for inside or
integrated at the outside of
the pods.



Sofa XL (see page 31)

fabric category 1
fabric category 2
fabric category 3
fabric category 4





MEETING POD XL

Suitable for 6 to maximum 8 people to fit in.

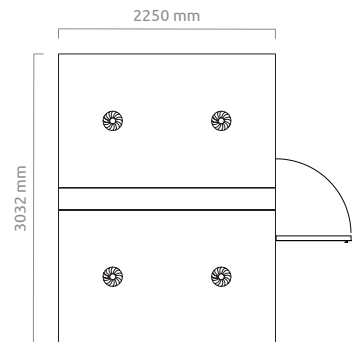

top view

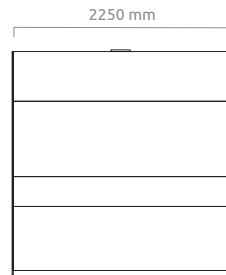

side view



front view



MEETING TABLES

Whether having a meeting at a high table with bar chairs, or at a low table with integrated sofas, there are options to integrate technology and to share or present via an LCD screen. Power sockets can be integrated with HDMI-, DATA- or USB ports to connect your laptop or other devices. See page 33.

TABLES AT THE SIDE

Due to the bigger space inside the Meeting pod XL there are more integration options for different meeting tables. By mounting a high meeting table at the side there is enough room for 6 bar chairs. With the extended table top mounted at both side 8 bar chairs is possible (extra door at the backside is required).



MEETING POD XL with glass backside



Price category 1:

fabric range soto, rebo

Price category 2:

fabric range wooly, organi, eco felt

Price category 3:

fabric range main line flax, laminated panels outside

Price category 4:

fabric range blazer, laminated acoustic panels inside

Included:

- 2x led-lights 5watt with sensor integrated in ceiling.
- air ventilation integrated in ceiling.
- door with hidden magnet closing.
- 1x integrated power socket.

Optional:

- extra power sockets (see page 33).
- integrated meeting tables, side tables, shelves and sofas.
- integrated magnetic white boards.
- integrated lcd-screen panels.
- water sprinkler integrated on request.

MEETING POD XL with upholstered panel at the backside



Price category 1:

fabric range soto, rebo

Price category 2:

fabric range wooly, organi, eco felt

Price category 3:

fabric range main line flax, laminated panels outside

Price category 4:

fabric range blazer, laminated acoustic panels inside

Included:

- 2x led-lights 5watt with sensor integrated in ceiling.
- air ventilation integrated in ceiling.
- door with hidden magnet closing.
- 1x integrated power socket.

Optional:

- integrated power sockets (see page 33).
- integrated meeting table, side tables, shelves and sofas.
- integrated magnetic white boards.
- integrated lcd-screen panels.
- water sprinkler integrated on request.

OPTIONS for Meeting pod XL



Side table & Shelf XL

table 500mm / 2140mm
shelf 250mm / 2140mm

hight 1050mm / low 750mm



Meeting table XL

low 750mm
high 1050mm

Sevaral table top dimensions



White board XL

Dimensions 2140mm x 780mm.
Available for inside or
integrated at the outside of
the pods.



LCD-screen panel XL

Dimensions 2140mm x 780mm.
Available for inside or
integrated at the outside of
the pods.



Sofa XL (see page 31)

fabric category 1
fabric category 2
fabric category 3
fabric category 4





TABLE INTEGRATION

There are different integration options for the side panels, like a tabletop that can be mounted in a high position combined with a bar chair, or in a low position in combination with a task chair. The back side of the POD is completely transparent.

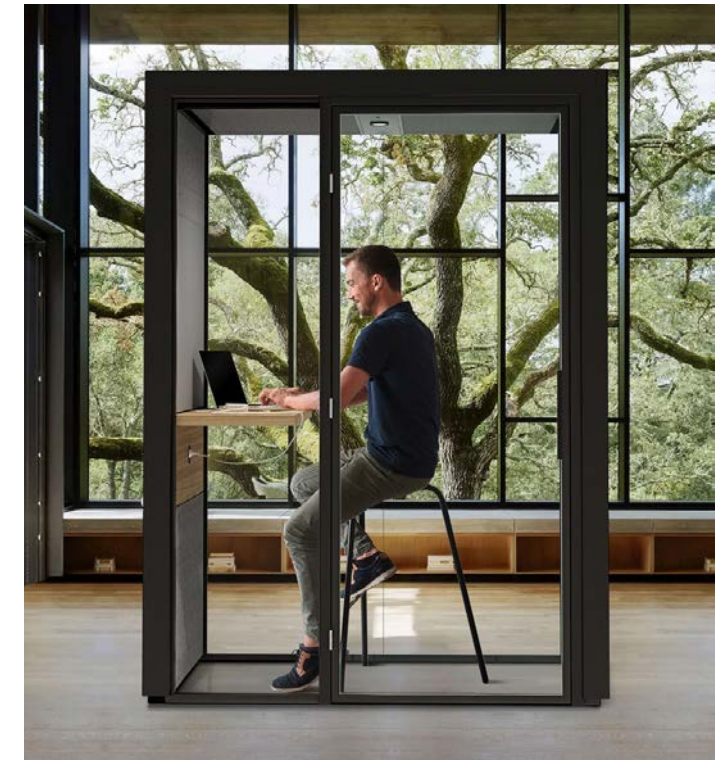

WORK POD

Suitable for 1 person to fit in.

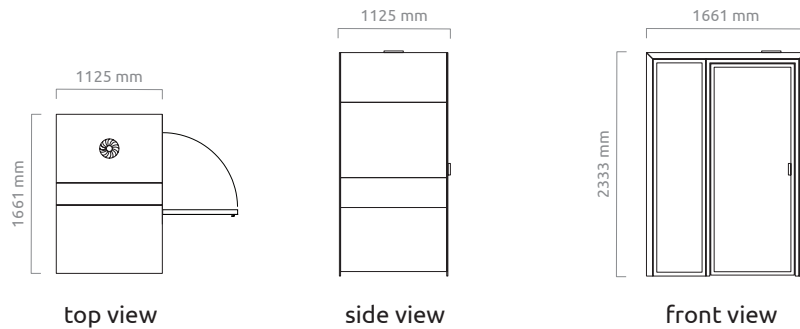



WORK POD LARGE

Suitable for 1 person to fit in.

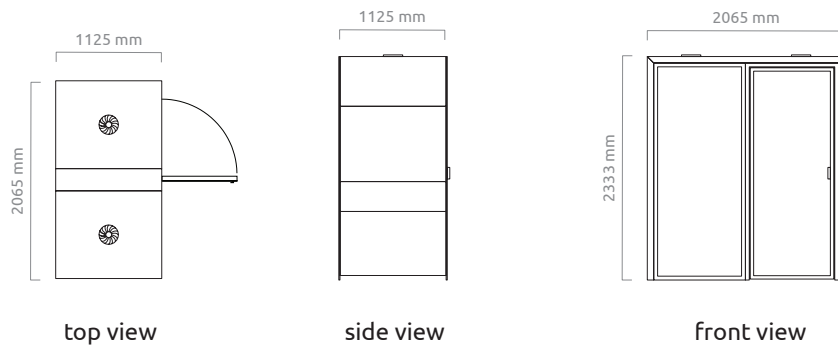

HIGHT ADJUSTABLE DESK

A small height adjustable desk is also an option to create a perfect work spot inside the Work pod. The power cord can be plugged inside the extra optional power socket(s) behind the desk integrated in the lower upholstered panel at the side.

TABLE INTEGRATION

There are different integration options for the side panels, like a tabletop that can be mounted in a high position combined with a bar chair, or in a low position in combination with a task chair. The back side of the POD is completely transparent.



WORK POD



Price category 1:

fabric range soto, rebo

Price category 2:

fabric range wooly, organi, eco felt

Price category 3:

fabric range main line flax, laminated panels outside

Price category 4:

fabric range blazer, laminated acoustic panels inside

Included:

- 2x led-lights 5watt with sensor integrated in ceiling.
- air ventilation integrated in ceiling.
- door with hidden magnet closing.
- 1x integrated power socket.

Optional:

- integrated power sockets (see page 33).
- integrated side table, shelf and sofa.
- integrated magnetic white boards.
- integrated lcd-screen panels.
- water sprinkler integrated on request.

WORK POD LARGE



Price category 1:

fabric range soto, rebo

Price category 2:

fabric range wooly, organi, eco felt

Price category 3:

fabric range main line flax, laminated panels outside

Price category 4:

fabric range blazer, laminated acoustic panels inside

Included:

- 2x led-lights 5watt with sensor integrated in ceiling.
- air ventilation integrated in ceiling.
- door with hidden magnet closing.
- 1x integrated power socket.

Optional:

- extra power sockets (see page 33)
- integrated side tables, shelves and sofa.
- integrated magnetic white boards.
- integrated lcd-screen panels.
- water sprinkler integrated on request.

OPTIONS for Work pod



Side table & Shelf short

table 500mm / 1010mm
shelf 250mm / 1010mm
high 1050mm / low 750mm



White board short

1120mm x 780mm
Available upon request for
inside and outside.



LCD-screen panel short

Available upon request for
inside and outside.



Sofa short (see page 31)

fabric category 1:
fabric category 2
fabric category 3
fabric category 4



WORK POD XL

Suitable for 1 or 2 persons to fit in.

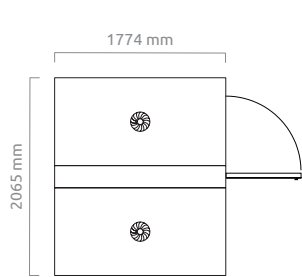

top view

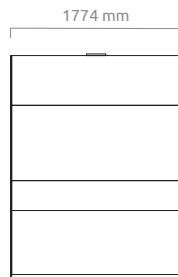

side view

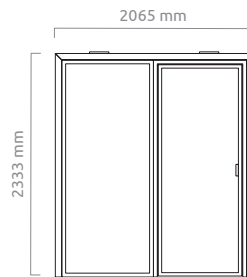

front view



HIGHT ADJUSTABLE DESK

A small height adjustable desk is also an option to create a perfect work spot inside the Work pod. The power cord can be plugged inside the extra optional power socket(s) behind the desk integrated in the lower upholstered panel at the side.

TABLE INTEGRATION

There are different integration options for the side panels, like a table top that can be mounted in a high position combined with a barchair, or in a low position in combination with a task chair.



WORK POD XL



Price category 1:

fabric range soto, rebo

Price category 2:

fabric range wooly, organi, eco felt

Price category 3:

fabric range main line flax, laminated panels outside

Price category 4:

fabric range blazer, laminated acoustic panels inside

Included:

- 2x led-lights 5watt with sensor integrated in ceiling.
- air ventilation integrated in ceiling.
- door with hidden magnet closing.
- 1x integrated power socket.

Optional:

- extra power sockets (see page 33).
- integrated side tables, shelf and sofa.
- integrated magnetic white boards.
- integrated lcd-screen panels.
- water sprinkler integrated on request

OPTIONS for Work pod XL



Side table & Shelf long

table 500mm
shelf 250mm

height 1050mm / low 750mm



White board long

Dimensions 1780mm x 780mm
Available upon request for
inside and outside.



LCD-screen panel long

Dimensions 1780mm x 780mm.
Available upon request for
inside and outside.



Sofa long (see page 31)

fabric category 1
fabric category 2
fabric category 3
fabric category 4



FLEX POD

Suitable for 1 person to fit in.

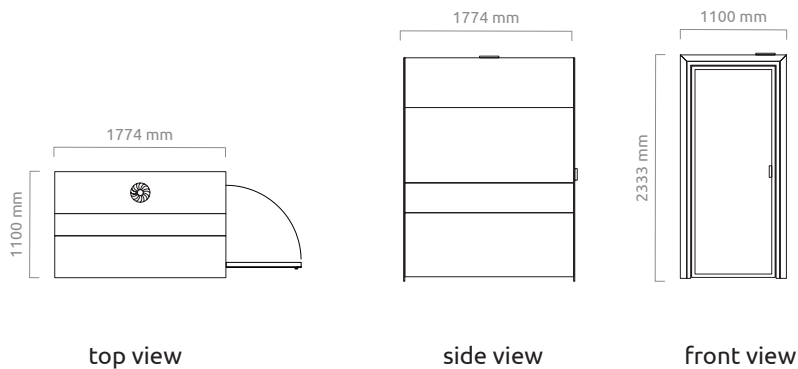

BRIDGE TABLE

The Bridge-table can be placed at two different heights depending if you want to sit at a bar chair or at a chair with casters.

At each sides there is an optional integrated power socket possible.



CONNECTED

The Flex pod offers a perfect solution when a single-user pod will be combined with a bigger pod for multiple users. See image below.



The Flex pod shares the same width as the Meeting pod and Work pod XL and can be perfectly combined as one unit to save space.

See more about connecting pods on page 26.

FLEX POD



Price category 1:

fabric range soto, rebo

Price category 2:

fabric range wooly, organi, eco felt

Price category 3:

fabric range main line flax, laminated panels outside

Price category 4:

fabric range blazer, laminated acoustic panels inside

Included:

- 2x led-lights 5watt with sensor integrated in ceiling.
- air ventilation integrated in ceiling.
- door with hidden magnet closing.
- 1x integrated power socket.

Optional:

- extra power sockets (see page 33).
- integrated bridge table and shelf.
- integrated magnetic white boards.
- integrated lcd-screen panels.
- water sprinkler integrated on request.

OPTIONS for Flex pod



Shelf long

shelf 250mm

height 1050mm / low 750mm



White board long

Dimensions 1120mm x 780mm.
Available for inside or
integrated at the outside of
the pods.



LCD-screen panel long

Dimensions 1120mm x 780mm.
Available for inside or
integrated at the outside of
the pods.



Bridge table short

890mm long / 700mm deep

height top 750mm or 1050mm from floor.



PHONE POD

Suitable for 1 person to fit in.

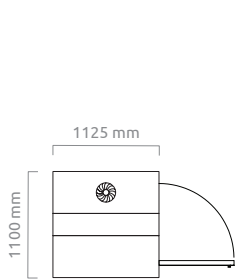

top view

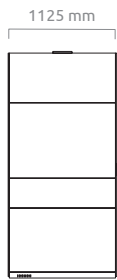

side view



front view



PHONE POD with glass backside



Price category 1:

fabric range soto, rebo

Price category 2:

fabric range wooly, organi, eco felt

Price category 3:

fabric range main line flax, laminated outside panels

Price category 4:

fabric range blazer, laminated acoustic panels inside

Included:

- 2x led-lights 5watt with sensor integrated in ceiling.
- air ventilation integrated in ceiling.
- door with hidden magnet closing.
- 1x integrated power socket.

Optional:

- integrated power sockets (see page 33)
- integrated shelf and high seat
- integrated magnetic white boards
- integrated lcd-screen panels
- water sprincler integrated on request

OPTIONS for Phone pod



Shelf short

shelf 250mm / 1010mm

high 1050mm / low 750mm



High seat 750mm high

fabric category 1
fabric category 2
fabric category 3
fabric category 4



White board short

1120mm x 780mm

Available for inside or integrated
at the outside of the pods.



LCD-screen panel short

1120mm x 780mm

Available for inside the pods.



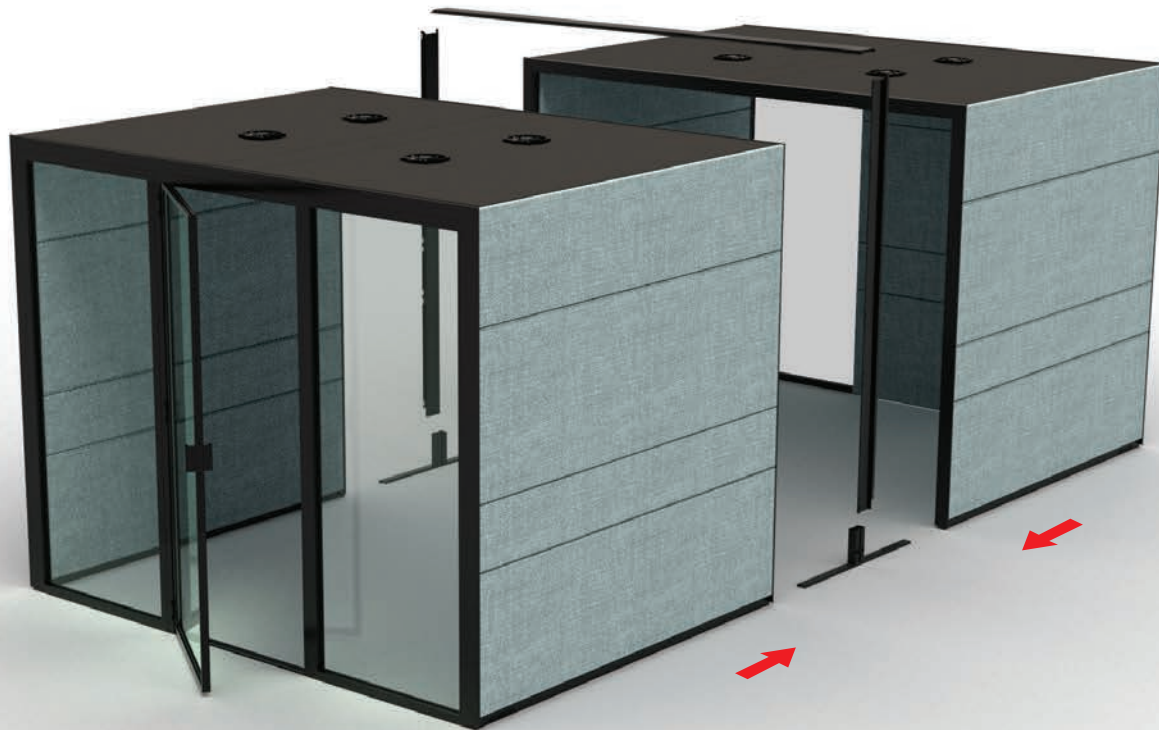

EXTENDING PODS

All the Meeting and Duo pods can be connected to each other to extend the pods. The standard parts remain the same, but the floor plinths at the back will be replaced for connection brackets at both sides in order to create a larger floor inside without any plinths in the middle.



(A) Connected pod with an extra door at back side



(B) Connected pod with upholstered mid-panel with table attached.



(C) Connected pod with transparent backside with three windows

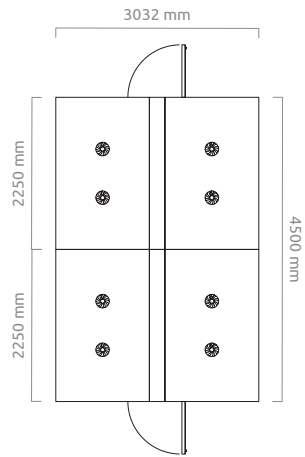

For 16 people maximum inside.

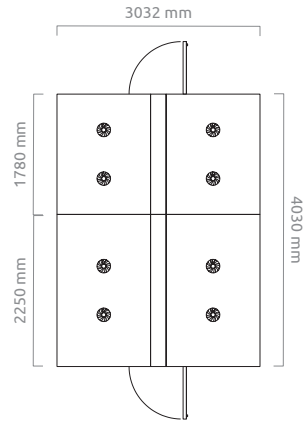

For 14 people maximum inside.

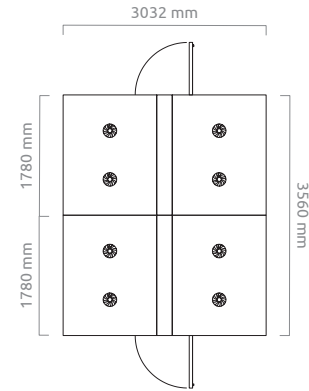

For 12 people maximum inside.

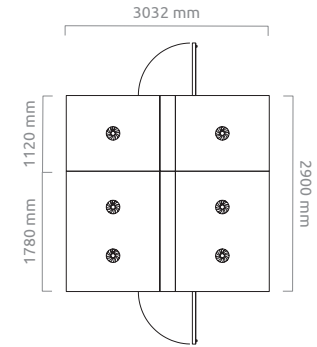

For 12 people maximum inside.

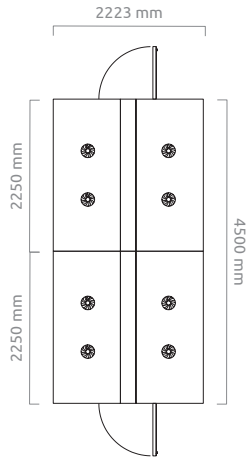

For 16 people maximum inside.

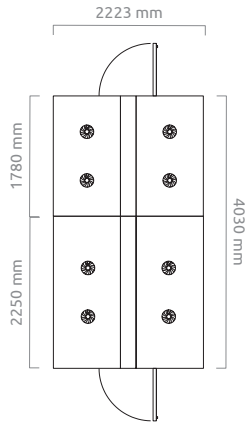

For 14 people maximum inside.

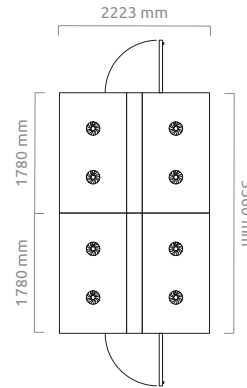

For 12 people maximum inside.

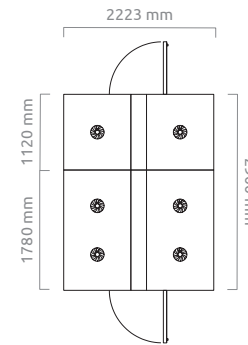

For 12 people maximum inside.

EXTENDING PODS

Create your own extended pod with a door at the front and back, or with an integrated meeting table or with transparent backside with three windows connected.

Prices for connected pods are available on request.



CONNECTING PODS TOGETHER

The pods with different dimensions can be connected next to each other. The small ventilation holes at the bottom remain open to ensure fresh air can enter the pods.

A small hole at each side in the ventilation plinth makes it possible to guide the power cords from one pod to the other. Also, on top the cables can be connected from one pod to the other pod.

Connecting pods together helps ensure an effective use of available space in the room.

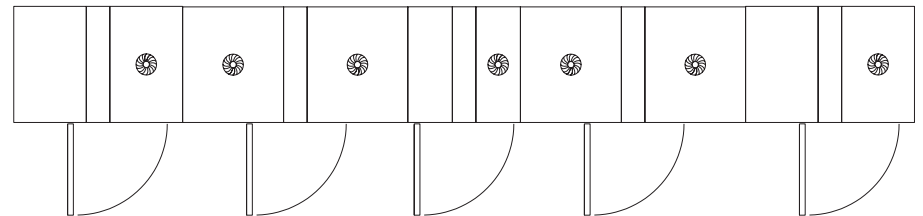

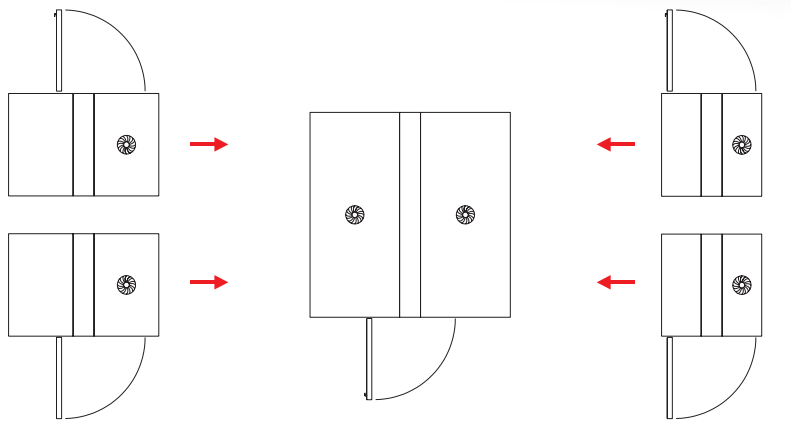

2x work pod

meeting pod large

2x phone pod

SHARING THE SAME GRID DIMENSIONS

The pods can also be placed back-to-back. The acoustic glass in between will not allow people to hear each other talking inside the adjacent pod.

Two Phone pods, Work pods or Duo pods in mirrored position share the same length as one Meeting pod Large or Meeting pod XL. A cluster with pods for single user or group of users can be combined in the same clustered block.

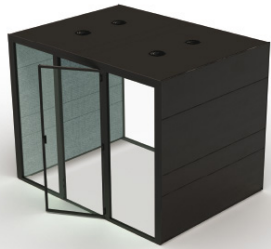

ADAPT THE DOOR DIRECTION

All the pods provide the option to change the door direction at location by rotating the door 180 degree and changing the left door cover with the right door cover.

This makes the pod fit in any floorplan possible, but also might be an unexpected necessity when the pod will be located to another place or when the surrounding interior will change in the future.

Door placed in the middle and turning left

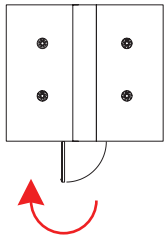

Door placed in the middle and turning right

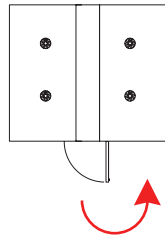

Door placed at the side (left & right possible)

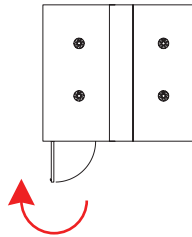

WHEELCHAIR ACCESSIBILITY

Most acoustic pods are not accessible for people in a wheelchair or using a walker. A raised floor is an obstacle that blocks older people or people with a physical handicap.

The eco pods of Ecolution don't have a raised floor and the 15mm high floor plinth is matching the European building certification standard. An extra rubber ramp can be added to make the pod even more accessible for wheelchairs and walkers.



Rubber doorstep ramp
900mm x 150mm x 15mm

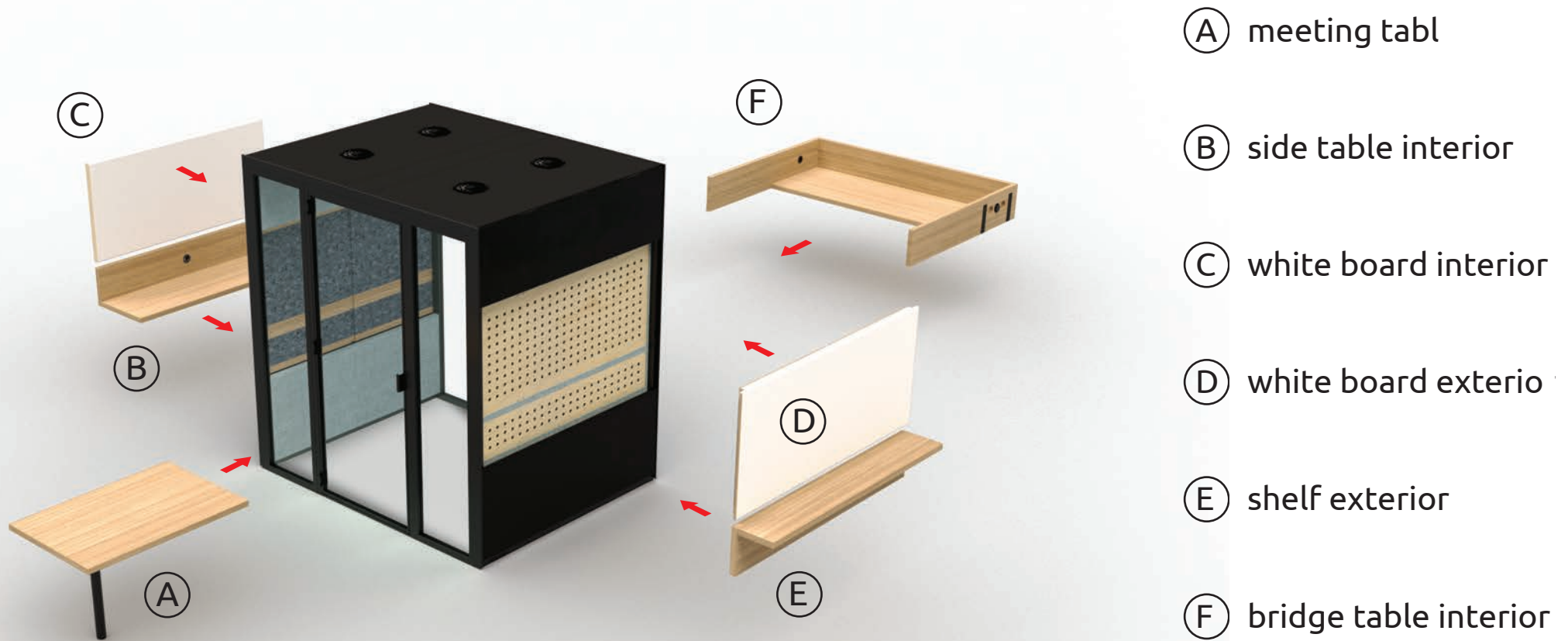

- Ⓐ meeting table
- Ⓑ side table interior
- Ⓒ white board interior
- Ⓓ white board exterior
- Ⓔ shelf exterior
- Ⓕ bridge table interior

FLEXIBLE INTERIOR & EXTERIOR

Besides the differing pod dimensions, you can choose several interior and exterior options like integrated tables for laptop support, LCD-screens for video calling, White boards for brainstorm sessions and perfectly comfortable upholstered sofas for longer meeting sessions. A wide variety of different colors and textures can be selected for the acoustic panels at the inside and outside of these pods.

All optional interior & exterior elements are part of the same modular concept.

Interiors can be adapted in the future extending the lifetime of the product. All integrated tables are made of 100% recycled wood and available in 6 different finishes. The magnetic whiteboards offer the best quality available with an enamel top layer to avoid scratches and old marks.

Explore the different options and customize your pod to match your personal standards..

INTEGRATED EXTERIOR OPTIONS



SIDE TABLE in high position

- in high position 1050mm from floor
- in low position 750mm from floor
- table top 500mm deep, 40mm thick
- outside or inside of the pod
- max 3x power module integrated
- 100% recycled wood
- available different length
- available in different colours



SHELF in high position

- in high position 1050mm from floor
- in low position 750mm from floor
- top 250mm deep, 40mm thick
- outside or inside of the pod
- max 3x power module
- 100% recycled wood
- available different length
- available in different colours



LCD-SCREEN PANEL

- outside or inside of the pod
- lcd-bracket not included
- cable grommet included
- 100% recycled wood
- available different length
- available in different colours



MAGNETIC WHITE BOARD

- outside or inside of the pod
- white enamel coated surface
- no magnets or markers included
- aluminum profile on top and bottom



INTEGRATED INTERIOR OPTIONS



SOFA

- seating height from floor 460mm
- seating depth 480mm
- frame made of recycled wood
- contains Eco foam
- fabric covers removable with zipper
- feet 20mm adjustable
- available different length
- available in different eco-fabrics see page 41



HIGH SEAT

- suitable for Phone pod
- seating height from floor 900mm
- frame made of recycled wood
- contains Eco foam
- fabric covers removable with zipper
- feet 20mm adjustable
- teel mounting hooks included
- available in different eco-fabrics see page 41



MEETING TABLE

- in high position 1050mm from floor
- in low position 750mm from floor
- top 800mm width, 40mm thick
- available different length
- column leg and bracket included
- table top 100% recycled wood
- available in different colours see page 49



BRIDGE TABLE

- in high position 1050mm from floor
- in low position 750mm from floor
- knock down packaging
- top 700mm deep, 40mm thick
- available different length
- 100% recycled wood
- available in different colours see page 49



INTEGRATED LIGHTING & VENTILATION

A small motion detection sensor integrated in the ceiling activates the ventilators in the roof and the integrated LED lights in the ceiling when entering the pod. The silent ventilators suck out the hot air creating an airflow from bottom to top. Cold air is coming in through small holes in the floor plinths refreshing the air inside the pod in 2 minutes time. The temperature inside the pods remains the same as the surrounding space when shared with other persons at the same time.

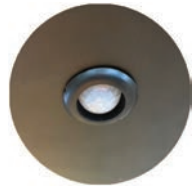

230 volt RA



ventilation slots



ventilators



7-watt led spots



ELECTRIFICATION & CABLE MANAGEMENT

The pods can be connected to the network of building from each side at the floor or from the ceiling if preferable. Pods with a Mid-panel integrated in the back have an extra option using a 60mm diameter grommet placed 3cm above the floor in the middle. Because the panels at the outside and inside of the pod can be removed, a cable channel inside the wall is accessible and cables can be guided in any direction. All pods will be delivered with a GST18 power block with four gangs and two five meter GST18 cables to connect the pod with power sockets to the building.



different power modules



power cables with gst18 plug



cable splitter for connecting



GST18 power block integrated in ceiling tray



INTEGRATED POWERSOCKET OPTIONS



POWER SOCKET STANDARD

- 230 volt RA
- including 20cm cable GST18
- 68mm diameter
- 56mm installation depth
- sockets for foreign countries
- available on request.



UTP Cat6 2x

- Two UTP ports included.
- 68mm diameter
- 56mm installation depth
- No cables included for ports at the backside



USB SPEED CHARGING

- 2x USB port include
- including 200mm cable GST18
- 68mm diameter
- 56mm installation depth
- For fast charging your phone, laptop or other diveces.



Cat6 UTP + 1x HDMI

- 1x UTP Cat6 port included
- 1x HDMI included
- 68mm diameter
- 56mm installation depth
- No cables included for ports at the backside



A

automatic drop-seal integrated in top and bottom of the door

B

gaps around the door closed with rubber profiles in door frame

C

sound absorbing labyrinth inside the floor plinths and between ceiling and roof panels



D

double layered 10,7mm thick glass panels with acoustic layer in between

E

110mm thick sound absorbing panels at both sides and at ceiling

F

50-shore rubber soft band underneath the floorplinths for different floor surfaces

ACOUSTIC PERFORMANCE

Don't take acoustics for granted. Confidential discussions should not always be shared with other people sharing the same room. Not only will the conversations of people inside the pods remain private, but also the people inside the pods will not be disturbed by conversations or other noises outside of the pod.

There are only three manufacturers in Europe that can offer an acoustic pod with the European standard for Acoustics in category A. Evolution is one of them!

The acoustic test report is available on request.

MAKE YOUR OWN

Furniture products and acoustic pods require not only a sustainable design today, but also have to offer a wide range of different colors and textures to match the high standards of a modern interior. The selection of colors in the working environment are often part of the corporate identity of the space.

Combinations of different textures create a perfect sense of ambiance and comfort for the people. Our mission is to offer maximum flexibility to select your own personal preferences, but also to make it possible to adapt the product in the future.

For each (removable) panel at the outside and inside of the meeting pods, a separate material, texture or color can be selected and even replaced for another new colorful texture in the future.

For the integrated sofas, several different ecofriendly fabric ranges have been selected offering a large scale of different colors. Similar to the sofas, the panels are also upholstered with removable covers.

A range of felt made of recycled textile offer 9 different unique colorful textures that can be combined with these fabrics or laminates.

The oak laminate finishes of the hard panels and integrated tables are available in several different tones from almost completely black to white wash oak.

If you can't find your color or texture from our standard collection, feel free to contact us for more options or technical advice of your own selected material.

We even offer the opportunity to collect your textile of your old interior and turn it into new felt with colors of your liking!



PANELS AT THE OUTSIDE

The outside of the pod is made of upholstered panels based on several different eco fabric ranges. Another option are panels laminated with felt made of textile waste. The third option is a choice of different finishes including four different woodgrain colors matching with the oak of the integrated tables.

Panels laminated in mat black is the third category making a perfect match with the RAL2005 black color of the aluminum frame.

All panel options are categorized in different price groups. Different panel materials can be mixed (prices on request).

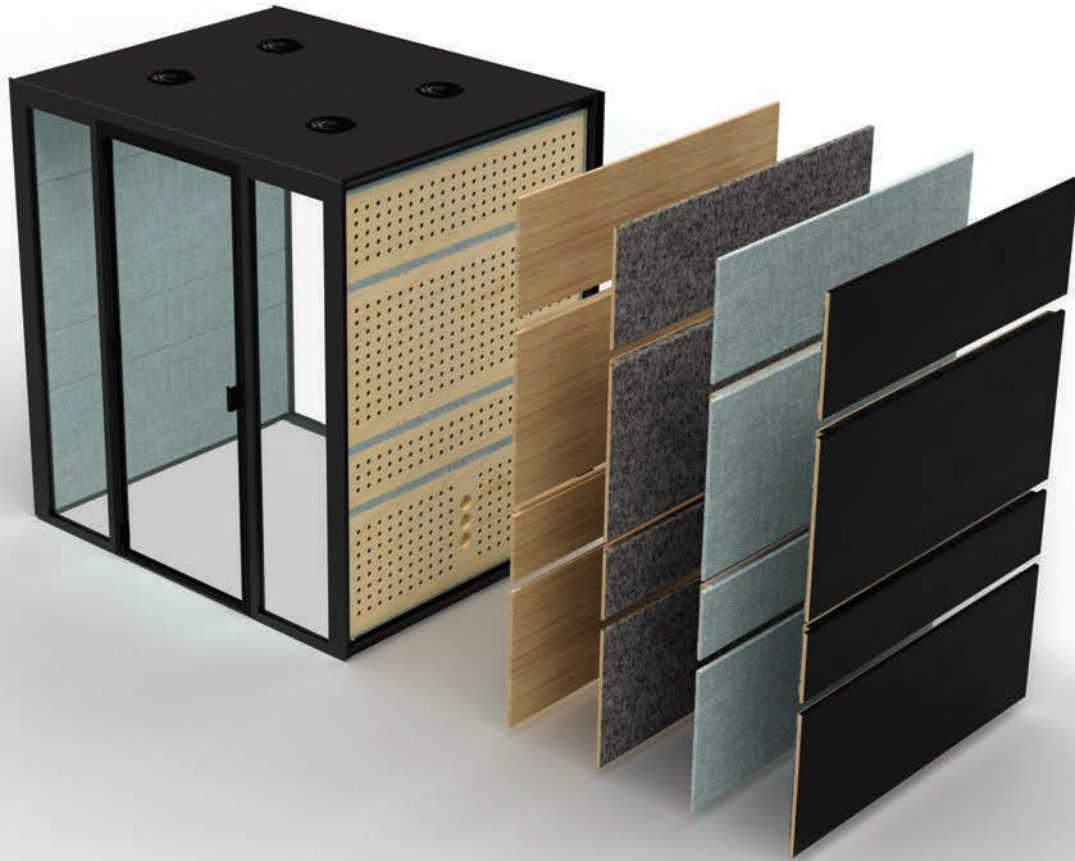

upholstered eco-fabric panels



upholstered eco-felt panels



laminated eco panels wood grain



laminated eco panels black and more

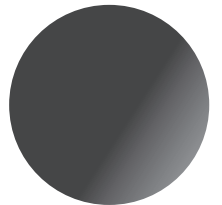

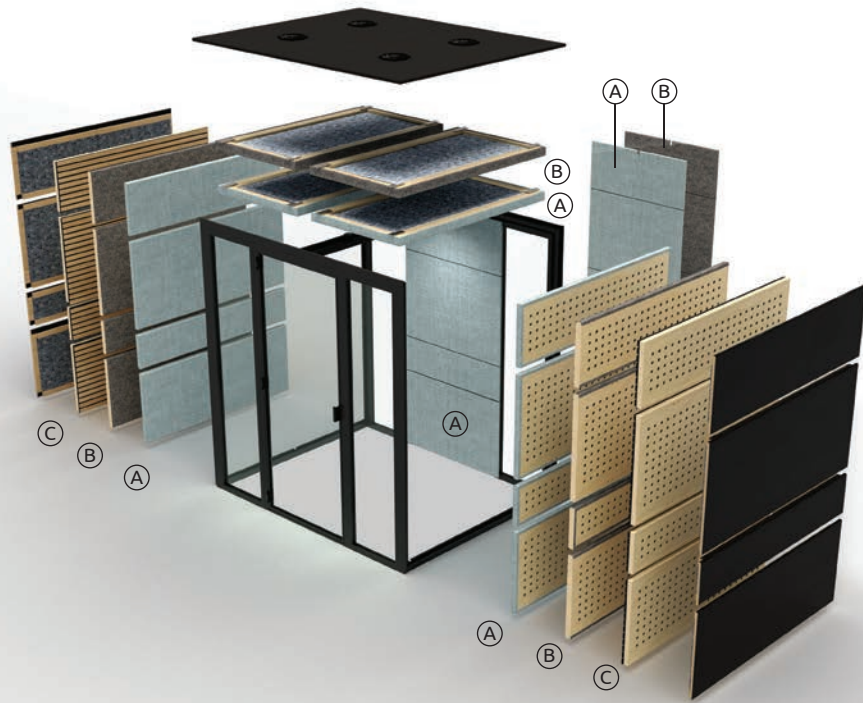

PANELS AT THE INSIDE

The panels at the inside of the pod are different from the panels at the outside, but share the same finishes except for the black solid panels and other laminated panels. These panels are not acoustic and can't absorb the soundwaves inside.

The woodgrain panels at the inside of the pods are different as well because the surface is perforated. These panels are acoustic due to this perforation. The core of the interior woodgrain panels is recycled MDF.

- Ⓐ eco-fabric panel
- Ⓑ eco-felt panel
- Ⓒ recycled wood panel



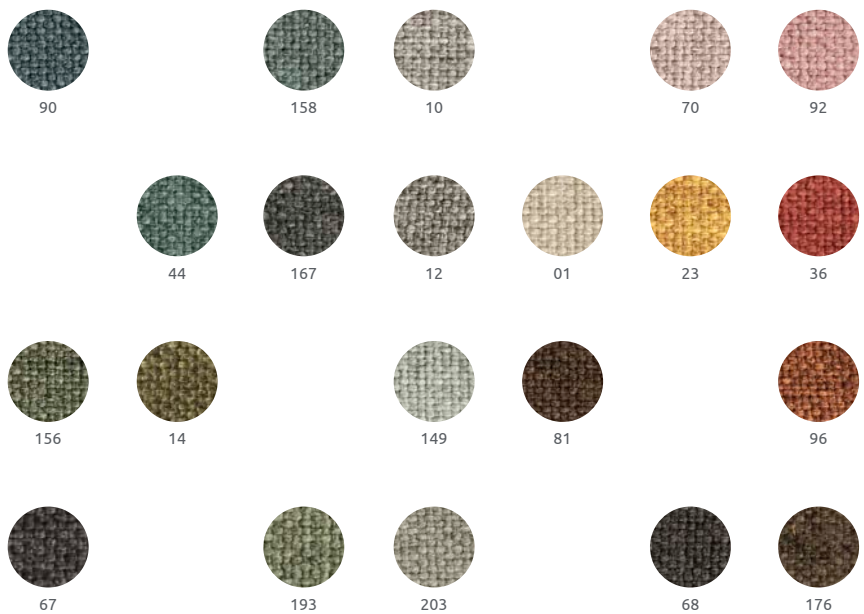

SOTO price category 1

Woven on an air jet loom, piece dyed and 60% sustainable – RPET- make this textile unique in its kind. It is soft, durable and has a fine woven structure. SOTO has a light melange and matt aspect and is made of plastic bottles waste.

Abrasion resistance: 100.000 Martindale

Weight: 600 g/m²

Flammability: EN 1021 1-2

Composition: 100% recycled PET (plastic bottles waste)



42% LESS
ENERGY



52% LESS
WATER



46% LESS
CO₂



60% WASTE
MATERIAL



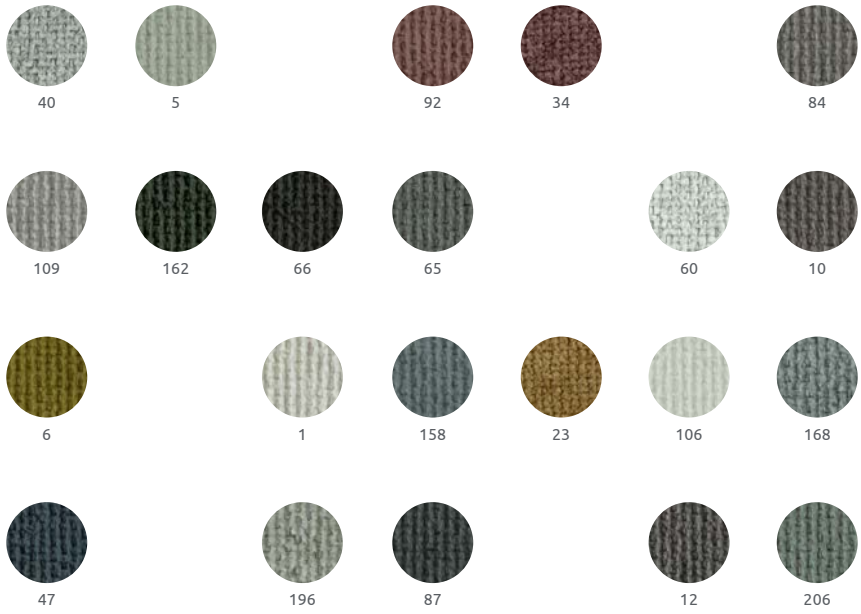

REBO price category 1

Woven on an air jet loom with micro-chenille yarns, these yarns provide a voluminous, chunky and comfortable handfeel. Rebo is piece dyed and suitable for all types of upholstery, such as loose covers, tight fitted or buttoned.

Abrasion resistance: 90.000 Martindale

Weight: 590 g/m²

Flammability: BS 5852

Composition: 96% recycled PET, 4% NY



59% LESS
ENERGY



74% LESS
WATER



35% LESS
CO₂



96% WASTE
MATERIAL



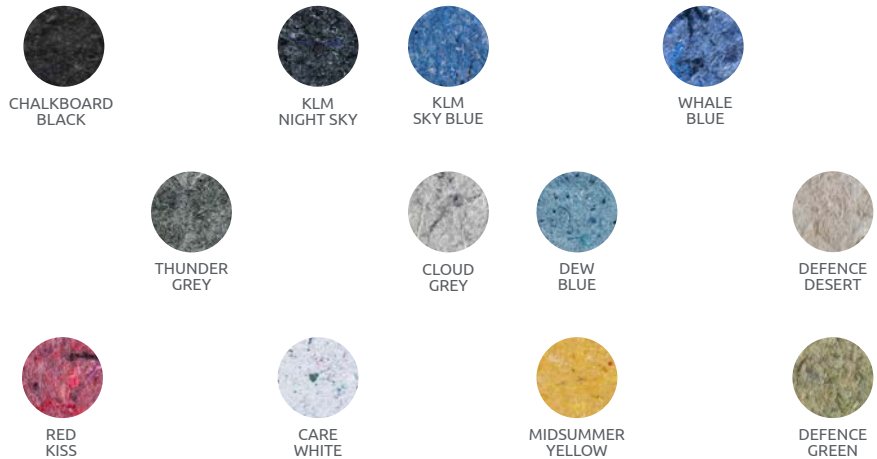

ECO FELT price category 2

Made of 100% recycled textile

FELT made from recycled textile consist of several different materials such as cotton, wool, flax, polyster and nylon.

Abrasion resistance: the felt is not suitable for upholstery of seats

Weight: 450 g/m²

Flammability: the felt can be impregnated for an upcharge matching the EN 1101 1-2 standard.

Composition: 100% recycled textile from different origin.



14% LESS ENERGY



98% LESS WATER



89% LESS CO₂



98% WASTE MATERIAL

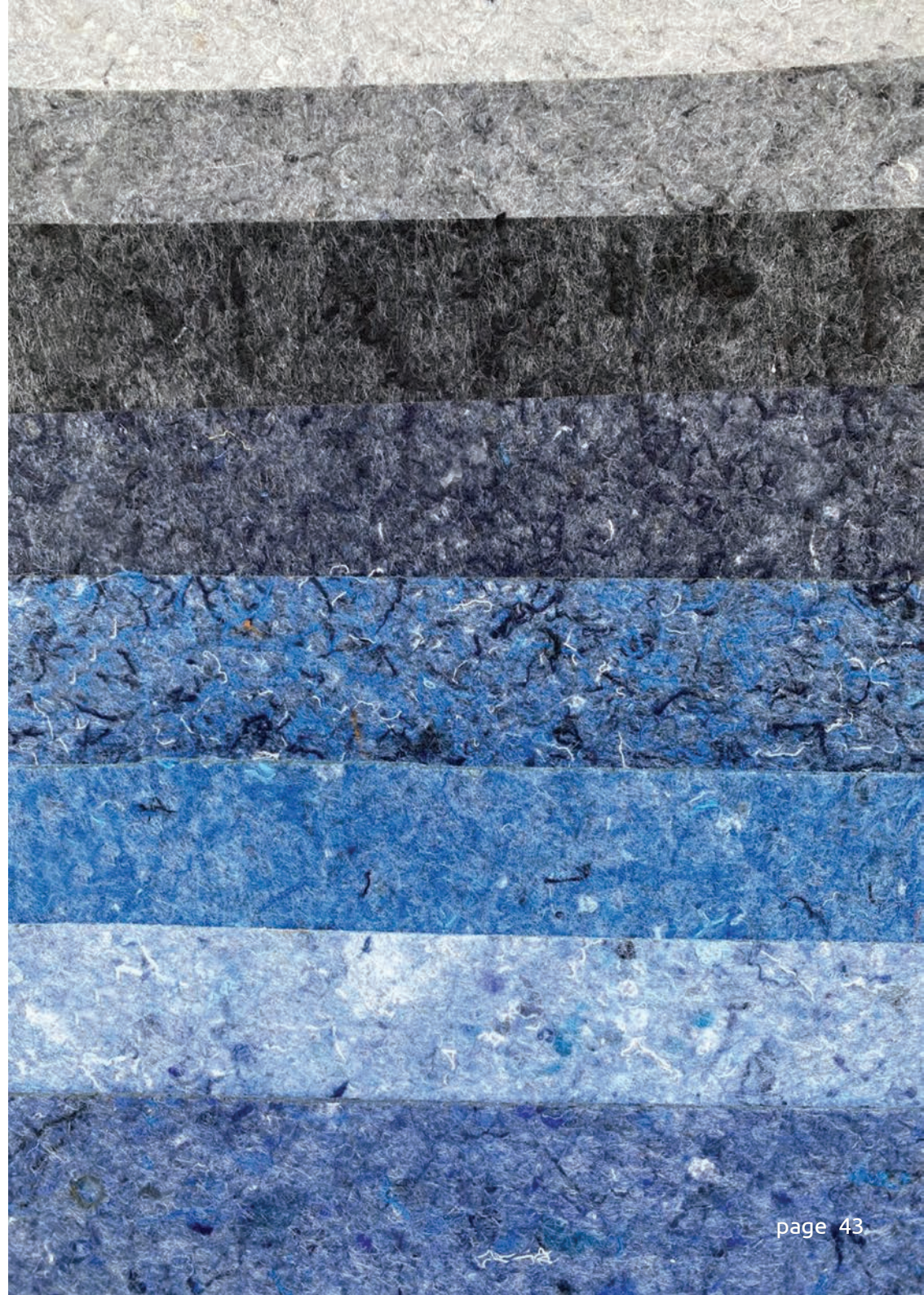

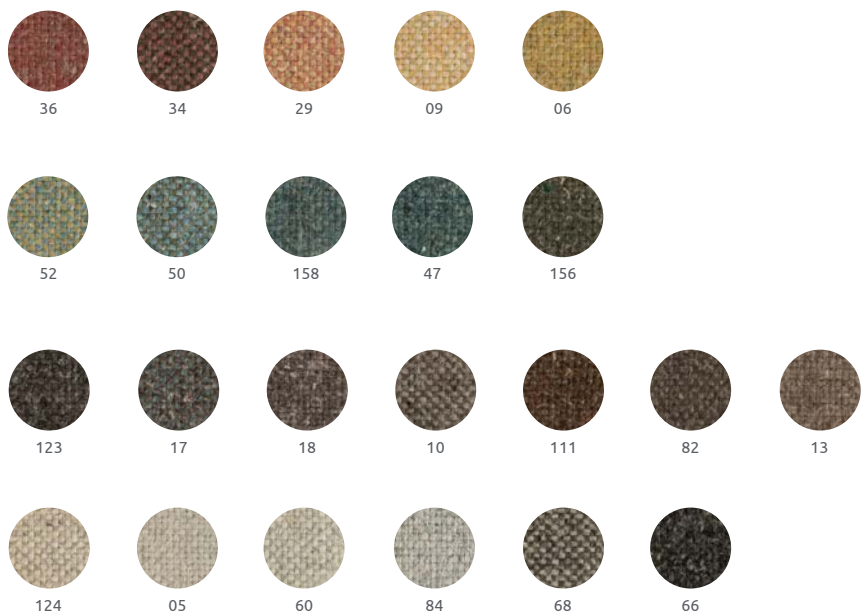

ORGANI price category 2

Organi is a luxury woven and sustainable fabric made from post-consumer wool, virgin linen and recycled polyamide.
 What makes this textile sustainable is the recycled post-consumer wool. The production process is environmental friendly and it gives previously used woolen products a second life.

Abrasion resistance: 100.000 Martindale

Weight: 550 g/m²

Flammability: BS 5852-part 1 / EN 1021 1-2

Composition: 50% Wool recycled / 20% PA recycled / 30% LI



64% LESS
ENERGY



22% LESS
WATER



89% LESS
CO₂



50% WASTE
MATERIAL



WOOLY price category 2

This post-consumer woolen upholstery fabric is suitable for all types of upholstery.

The yarns of WOOLY are made from post-consumer recycled woolen textiles and virgin polyamide.

The recycled yarns are carded from regenerated woolen products. Carding is a specific way of processing yarns.

Due to an environmental friendly production process, used woolen clothing, fabrics & knits get a second life.

Abrasion resistance: 100.000 Martindale

Weight: 600 g/m²

Flammability: EN 1021 1-2

Composition: 70% Wool recycled / 25% PA recycled / 5% OF



82% LESS
ENERGY



31% LESS
WATER



92% LESS
CO₂



70% WASTE
MATERIAL

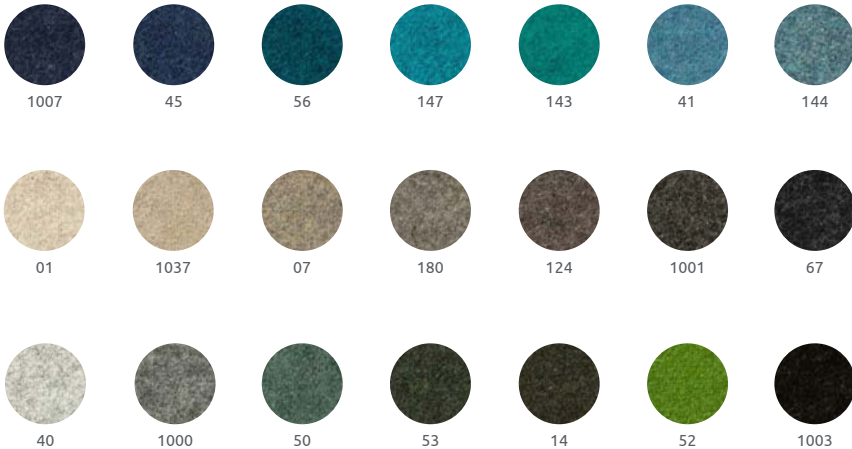

MAIN LINE FLAX CAMIRA - price category 3

70% Virgin wool - 30% Flax / 100% biodegradable

Main Line Flax, made from 70% wool and 30% flax fibre continues our world leading progress in the design manufacture and distribution of fabrics made from blends of bast fibre and wool. A simple, hardwearing plain weave structure, Main Line Flax is a new, sustainable take on a well-loved and trusted classic available in a palette of 41 shades.

Abrasion resistance: 50.000 Martindale

Weight: 437 g/m²

Flammability: EN 1021 1-2

Composition: 70% Virgin Wool, 30% flax (100% biodegradable).



BLAZER price category 4

100% Virgin wool / 100% biodegradable

Wool is a proven textile fibre with genetically in-built high performance attributes, evolved from nature over thousands of years. It takes the least energy consumption of all the major fibre groups to be converted into usable textile fibre and is both rapidly renewable and biodegradable.

Abrasion resistance: 50.000 Martindale

Weight: 460 g/m2

Flammability: EN 1021 1-2

Composition: 100% Virgin Wool (100% biodegradable).



LEED Credit Contributor : LEED v3

- MRc2.2 Sustainable purchasing - furniture (over 50% rapidly renewable material)
- MRc5 Regional Materials (depending on distance of project location)
- MRc6 Rapidly Renewable Materials (100% wool)

Information on contribution to other green building schemes is available

GIGA Ranked

'Green Ideas Green Actions' is a tool for architects and designers to choose the most

environmentally sensitive materials for their projects.

Blazer is a top ranked GIGA material with verified Green Claims.

• Biodegradable

Manufacturing Location - Huddersfiels, United Kingdom

Raw Materials – Wool extracted from New Zealand

Facility systems – ISO 14001, ISO 9001, OHSAS 18001. Waste to landfill 0%



LAMINATED WOODGRAIN PANELS OUTSIDE

Beside the upholstered panels we offer also laminated panels made of 100% recycled wood in four different Oak finished. These woodgrain colours are the same as the laminated integrated tables. Both can be recycled again.

Panels laminated with real oak veneer are available on request.



light oak op
price category 3



natural oak op
price category 3



fumed oak op
price category 3

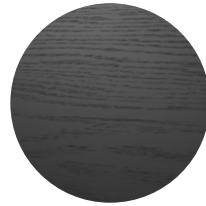

black oak op
price category 3

LAMINATED WOODGRAIN ECO PANELS INSIDE

The wood panels at the inside of the pod are different from the wood panels at the outside, but share the same woodgrain finishes. The surface is perforated in order to absorb the internal sound waves by the acoustic recycled textile between the inside and outside panels. Inside the 9mm deep grooves the black core of the recycled MDF is visible creating a beautiful pattern of horizontal lines that camouflage the little acoustic holes.



light oak ip
price category 4



natural oak ip
price category 4



fumed oak ip
price category 4



black oak ip
price category 4



LAMINATED ECO PANELS OUTSIDE

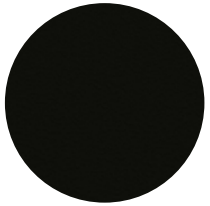

black mat
price category 3

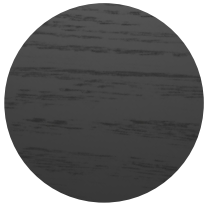

black oak
price category 3



brushed gold
price category 3

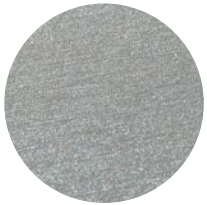

brushed aluminum
price category 3



brushed bronze
price category 3



brushed metal blue
price category 3

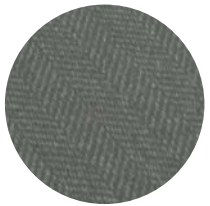

moss grey
price category 3

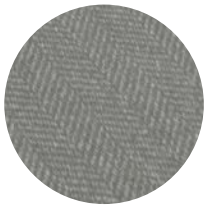

slate grey
price category 3



wool beige
price category 3

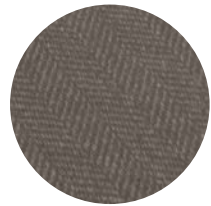

brown weave
price category 3

brushed gold



wool beige

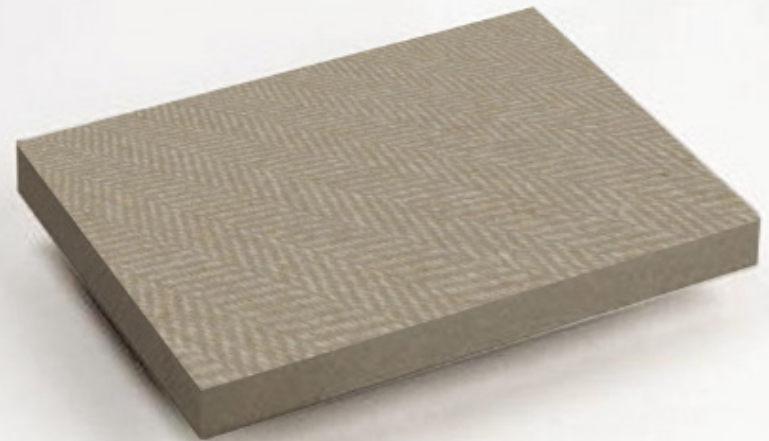

TABLE & SHELF FINISHES RECYCLED



light oak



natural oak



fumed oak

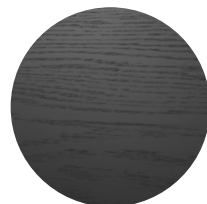

black oak

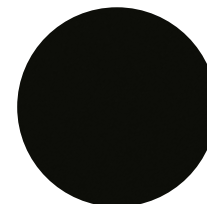

matt black

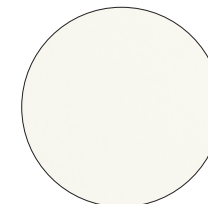

white



side tables



shelves



meeting tables



bridge tables



SUSTAINABLE PACKAGING

The world is changing faster than ever before. Climate change is forcing us to design and manufacture products in a different way with more awareness of the impact on our environment and society. These two principles are strongly related and determine the pillars of our organization. Making sustainable products with social consciousness.

GENERAL DELIVERY TERMS

1. Definitions

"the Supplier" means Ecolution-Design BV, Arnhemseweg Zuid 274 B, 3817 CR Amersfoort, The Netherlands "the Client" means the person, firm or company to be supplied with the Goods by the Supplier "Goods" means the goods, materials and/or other items to be supplied pursuant to the Contract "Contract" means the contract, order confirmation or order for sale and purchase of the Goods made between the Supplier and the Client to which these conditions apply.

2. Scope

These Conditions apply to all sales of Goods by the Supplier and shall prevail over any inconsistent terms or conditions contained or referred to in the Client's order or in correspondence or elsewhere, unless specifically agreed to in writing by the Supplier and any conditions or stipulations to the contrary are hereby excluded or extinguished.

3. Quotations

A quotation by the Supplier does not constitute an offer and the Supplier reserves the right to withdraw or amend the same at any time prior to the Supplier's acceptance of the Client's order.

4. Prices

The prices payable for the Goods shall (unless otherwise agreed upon in writing) be the Supplier's list prices therefore at the time of despatch.

5. Terms of payment

- a. Payment of invoices shall be made without any deduction or set-off in cash so as to be received by the Supplier not later than 14 days unless otherwise agreed in writing. Supplier shall have the right to claim and be paid interest at the rate of 12,5 percent per annum calculated on a day-to-day basis on all sums due to Supplier and unpaid for the period upon which payment is due until the date upon which payment is made both before and after any judgement.
- b. Nothing herein shall entitle the Client to withhold or delay any payment due to the Supplier after the date upon which it falls due or in anyway prejudice or affect Supplier's rights in relation to the said non-payment.
- c. If in the case of the Contract or any order involving more than one delivery default is made in payment on the due date the Supplier shall have the right - without prejudice to any other remedy which Supplier may have - to suspend all or any further deliveries pending payment or to terminate the Contract in its entirety by notice in writing to the Client.

6. Delivery

- a. Delivery dates mentioned in any quotation or acceptance form or elsewhere are approximate only and not of any contractual effect and the Supplier shall not be under any liability to the Client in respect of any failure to deliver on any particular date or dates. If delivery shall not have taken place within a reasonable time the Supplier's liability shall be limited to the value of the Goods specified in the Supplier's quotation or (where there is no quotation) the Supplier's acceptance of order. The Supplier shall not be required to deliver the Goods unless the Client shall have paid all sums then due and payable by the Client to the Supplier.
- b. If the Client refuses or fails to take delivery of Goods tendered in accordance with the Contract the Supplier shall be entitled to immediate payment in full for the Goods so tendered. The Supplier shall be entitled to store at the risk of the Client any Goods of which the Client refuses or fails to take delivery and the Client shall in addition to the purchase price pay all costs of such storage and any additional cost or carriage incurred as a result of such refusal or failure.
- c. The Goods shall unless delivered by the Supplier's own transport or by a carrier on behalf of the Supplier be deemed to have been delivered and the risks therein to have passed to the Client upon their transfer to the carrier named by the Client or (in the case of delivery "ex works") upon the Supplier notifying the Client that the Goods are available for collection.
- d. Where the Goods are to be delivered by the Supplier's own transport or by a carrier on behalf of the Supplier the risk therein shall pass to the Client upon delivery. The choice of route and mode of carriage shall be at the discretion of the Supplier. The Supplier shall advise the Client of the scheduled date of despatch from the Supplier's works and unless the Client notifies the Supplier in writing within 28 days the Supplier shall not be liable for any loss of or damage to the Goods in transit nor for failure of the Goods to be delivered and such Goods shall be deemed to have been delivered in good order and condition.

7. Title

- a. Supplier has the extensive title of the Goods. If there is any invoice from Supplier to Client unpaid and will remain unpaid, Supplier has the title of all former delivered Goods in possession of Client even if these Goods are fully paid. This is also called extensive reservation of ownership.
- b. Title to the Goods shall not pass to the Client until payment in full of the price therefore. Until such payment the Client shall have possession of the Goods as bailee for the Supplier and shall store the Goods in such a way as to enable them to be identified as the property of the Supplier provided that if the Client is purchasing the Goods for resale the Client may as agent for the Supplier sell and deliver the Goods to a third party in the ordinary course of the Client's business on condition that until such payment as aforesaid the Client shall hold all proceeds of such sales in trust for the Supplier and in a separate account. The Client hereby assigns to the Supplier all rights and claims which the Client may have against its customers arising from such sales until payment is made in full as aforesaid.

c. The Supplier reserves the right to re-possess any Goods in respect of which payment is overdue and thereafter to re-sell the same and for this purpose the Client hereby grants an irrevocable right and licence to the Supplier's servants and agents to enter upon all or any of its premises with or without vehicles during normal business hours. This right shall continue to subsist notwithstanding the termination of the Contract for any reason and is without prejudice to any accrued rights of the Supplier there under or otherwise.

8. Variations Slight deviations in quality, symmetry, format, colour, hardness, satin-finish and opacity shall not constitute grounds for rejection of the Goods by the Client.

9. Packaging

Packaging shall will be charged as Supplier uses special packaging. Packaging materials as such are returnable to Supplier and when fully returned a deposit will be refunded to Client. Costs for returning the packaging are on behalf of Client, unless otherwise agreed upon in writing or when given to Suppliers carrier during next delivery.

10. Third Party Rights

- a. The Client shall indemnify the Supplier against any and all claims costs demands and expenses incurred by or made against the Supplier as a direct or indirect result of the carrying out of any work required to be done on or to the Goods in accordance with the requirements or specifications of the Client involving any infringement or claim of infringement of any intellectual or industrial property right vested in any third party.
- b. In any case where the Goods are or are capable of becoming the subject of any industrial or intellectual property right of any third party the Supplier warrants that it shall transfer to the Client only such title as it may have to the Goods.

11. Warranty

- a. All Goods are sold on the understanding that Client will independently determine that the total quality and make-up of the Goods (including all adhesives, face materials, slitting tolerances, and resistance to environmental conditions) are suitable for his particular purpose.
- b. For his particular purpose all information, recommendations and descriptive material about Supplier's Goods are based upon research and tests believed to be reliable. They are intended only as a source of information and are given without guarantee and do not constitute a warranty.
- c. No salesman, representative or agent is authorized to give any guarantee, warranty, or make any representation contrary to the foregoing.
- d. Supplier's goods are manufactured under careful quality control. Without prejudice to the above provisions, the Supplier warrants that the delivered goods are free from defects in material and workmanship. The fact that delivered goods do not meet this warranty shall be communicated in writing to the Supplier within six weeks after delivery, or, if a period in deviation of this six weeks period has been agreed between the parties or is stated in the relevant product literature, within that period. The warranty obliges the Supplier exclusively to repair or replace the Goods, at the Supplier's option or, in the event that repair or replacement in the opinion of the Supplier is not practicable, commercially or otherwise, to issue a credit note to the Client not in excess of the original purchase price of the Goods.

12. Liability

- a. The Supplier shall not be liable to the Client:
 - i. for shortages of quantity delivered unless the Client notifies the Supplier of any claim for short delivery within 28 days of receipt of the Goods.
 - ii. for damage to or loss of the Goods or any part thereof in transit (where the Goods are carried by the Supplier's own transport or by a carrier on behalf of the Supplier) unless the Client shall notify the Supplier of any such claim within 28 days of receipt of the Goods or the scheduled date of delivery whichever shall be the earlier.
 - iii. for defects in the Goods caused by any act, neglect or default of the Client or of any third party.
 - iv. for other defects in the Goods resulting from faulty material or workmanship unless notified to the Supplier within 28 days of receipt of the Goods by the Buyer and before the Goods are processed or used or where the defect would not be apparent on reasonable inspection within the warranty period as described in Condition 11 d.
- b. The Supplier may at its option make good any shortage or non-delivery and/or as appropriate replace or repair any Goods found to be damaged or defective by reason of faulty material or workmanship provided that as a condition thereof the Supplier may require that the Goods concerned are returned to the Supplier within 28 days of discovery of the damage or defect.
- c. The Supplier's aggregate liability to the Client whether for negligence breach of contract misrepresentation or otherwise shall in no circumstances exceed the cost of the defective, damaged or undelivered Goods determined by net price invoiced to the Client in respect of any occurrence or series of occurrences.
- d. Subject to the foregoing all conditions, warranties and representations expressed or implied by statute common law or otherwise in relation to the Goods are hereby excluded and the Supplier shall be under no liability to the Client for any loss damage or injury direct or indirect resulting from defective material faulty workmanship or otherwise howsoever arising and whether or not caused by the negligence of the Supplier, its employees or agents.

GENERAL DELIVERY TERMS

13. Force Majeure

a. The Supplier shall not be liable to the Client for any loss or damage which may be suffered by the Client as a direct or indirect result of the Supplier being prevented, hindered or delayed in the performance of its obligations under the Contract by reason of any force majeure circumstances.

b. In this Condition "force majeure circumstances" shall mean any Act of God, war riot, strike, lock-out, trade dispute or labour disturbance, epidemic, accident, breakdown of plant or machinery, fire, explosion, flood, drought, government action, difficulty in obtaining workmen, materials or transport or other circumstances whatsoever outside the control of the Supplier affecting the provision of the Goods and services hereunder or of materials therefor by the Supplier's usual source of supply or the manufacture of the Goods by the Supplier's normal means or the delivery of the Goods by the Supplier's normal route or means of delivery.

14. Termination

If the Client enters into a deed of arrangement or commits an act of bankruptcy or compounds with his creditors or if a receiving order is made against him or (being a company) he shall pass a resolution or the Court shall make an order that the Client shall be wound up (otherwise than for the purposes of amalgamation or reconstruction) or if a receiver shall be appointed of any of the assets or undertaking of the Client or if the circumstances shall arise which entitle the Court or a creditor to appoint a receiver or manager or which entitle the Court to make a winding up order or if the Client takes or suffers any similar action in consequence of debt or commits any breach of any part of the Contract the Supplier may stop any Goods in transit and suspend further deliveries and by notice in writing to the Client may forthwith determine the Contract without prejudice to the provisions of Conditions 5 c and 7 b thereof and to any existing claim.

15. Waiver

The failure on the part of the Supplier to exercise or enforce any rights conferred by the Contract shall not be deemed to be a waiver of any such right nor operate so as to bar the exercise or enforcement thereof at any time or times thereafter.

16. Notices

Any notice required to be given hereunder in writing shall be deemed to have been duly given if sent by prepaid first class post (airmail where the addressee is abroad) telex or telegraph addressed to the party concerned at its principal place of business or last known address.

17. Headings

Headings to any of these Conditions are included to facilitate reference only and shall not affect the construction hereof.

18. Governing Law

The Contract shall be governed by and construed and interpreted in accordance with Dutch law and for the purpose of settlement of any dispute arising out of or in connection with the Contract the parties hereby submit themselves to the jurisdiction of the Utrecht, The Netherlands Courts.

ecolution

Ecolution-Design B.V.
Deventerstraatweg 17A
7311 BH Apeldoorn
The Netherlands

Rabobank
IBAN NL02RABO 0352 3683 30
CoC 77658310
VAT NL861084299B01

Factory Ecolution
Egerlaan 15
7334 AD Apeldoorn
The Netherlands

Contact:

info@ecolution.nl
www.ecolution.nl